

Model 830 Disposable Fluid Path Valve

Dispensing Valve Provides Larger Flow Rates While Maintaining Precision

- Ideal for low-to-high viscosity fluids
- Features a disposable fluid path that carries materials from the material reservoir to the dispense tip
- Fluids remain contaminate free in fluid path during dispensing
- Disposable fluid path prevents air entrapment during the dispensing process
- Valve design allows for easy product changeover with minimal cleanup
- Fluid never comes into direct contact with the valve, reducing valve maintenance and extending the life of the valve
- Over-pinch adjustment prevents damage to the tube, extending its life, and cutting down on necessary replacement
- Adjustable suck-back control eliminates drooling and filming over of the nozzle for a clean, drip-free dispense when dispensing thin or stringy materials
- Compatible with most standard fluid packages and delivery systems
- Lightweight, easy-to-handle and mount in automated or bench-top systems

The Model 830 normally closed disposable fluid path valve is designed to provide larger material flow rates while still maintaining precise control. This dual-piston pinch valve is used with many low- to high-viscosity materials and features a suck-back control to handle stringy and tacky materials with no mess.

The valve's main feature is its disposable fluid path which carries materials from the material reservoir to the dispense tip. Fluids are sealed within the fluid path, preventing contact with the valve's inner components and ensuring a contaminate-free dispensing process. The fluid path is easy to replace and requires minimal clean up, allowing for rapid material changeover. The standard Model 830 valve is supplied with 0.375" [9.53 mm] OD black polyethylene tubing.

The Model 830 valve can be integrated into an automated dispensing system and controlled with a three-way solenoid valve or paired with the Dymax DVC-345 Digital Valve Controller and a material reservoir to create a bench-top dispensing system.



Specifications

Valve Type	Pneumatic pinch valve, normally closed
Valve Materials	Anodized Aluminum
Operating Air Pressure	60-100 psi (4-7 bar)
Activation	DVC-345 valve controller or 3-way solenoid valve
Maximum Inlet Fluid Pressure	Up to 100 psi
Electrical Supply (345 Controller)	110-240 VAC
Maximum Operating Temperature	104°F (40°C)
Maximum Tubing Size	0.375" (9.53 mm) OD
Valve Dimensions (W x H x D)	With Fittings & Hardware: 4.75" x 3.25" x 1.75" (12.1 cm x 8.25 cm x 4.45 cm) Valve Body Only: 3.125" X 3.125" x 1.75" (7.94 mm x 7.94 mm x 4.45 cm)
Valve Weight	1.5 lbs. (0.68 kg)
Warranty	1 year from purchase

Figure 1. Model 830 Dimensions

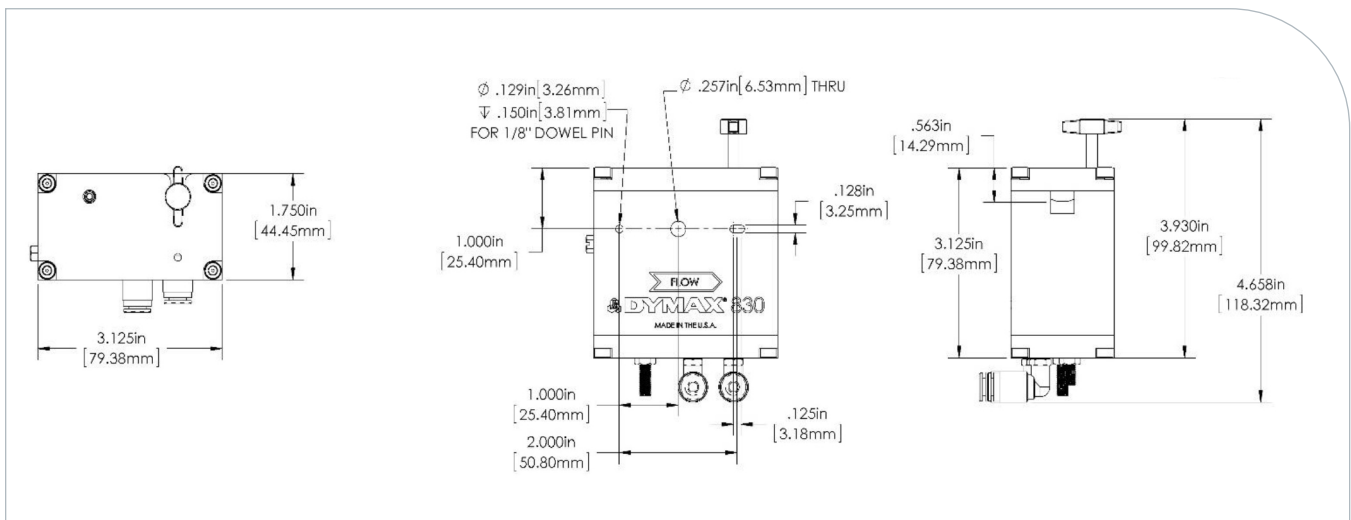

Available System Packages

Systems Include:

- Model 830 Dispensing Valve
- Selected Reservoir for Fluid Package Used
- Dispensing Tip Kit for Low Viscosity Fluids
- DVC-345 Digital Valve Controller
- Air Filter/Regulator - 0-100 psi (0-6.9 bar)
- Controller Air Line Kit
- Fluid Line Kit - 6 ft of Black 1/4" (6.3 mm) OD tubing and 3/8" - 1/4" (9.5 mm - 6.3 mm) reducer and two 3/8" - 1/4" (9.5 mm - 6.3 mm) stem fitting inserts
- Valve Mounting Assembly
- Lab Stand
- Reservoir Air Line Kit
- Fluid Line Kit - 6 ft of black 3/8" (9.5 mm) OD tubing
- Dispensing Tip Kit for Medium to High Viscosity Fluids

System Part Numbers Based on Fluid Package Used							
Valve Only	Complete System Without Reservoir	Cartridge Drop-In			Large Bottle Drop-In	Mini Ram Pump	Pail Drop-In
		6 oz [160 mL]	12 oz [300 mL]	20 oz [550 mL]	Up to 1 Gallon	Up to 3.8 Liters	Up to 15 Liter Straight or Taper
							
T18196	T18538	T18543	T18544	T18545	T18546	T17852	T18547



6 oz (160 mL)



12 oz (300 mL)



20 oz (550 mL)

Cartridge Drop-In Reservoirs



Bottle Drop-In Reservoir



Pail Drop-In Reservoir



Mini Ram Pump

