

Model 830 Disposable Fluid Path Dispensing Valve

User Guide



About Dymax

Light-curable adhesives. Systems for light curing, fluid dispensing, and fluid packaging.

Dymax manufactures industrial adhesives, light-curable adhesives, epoxy resins, cyanoacrylates, and activator-cured adhesives. We also manufacture a complete line of manual fluid dispensing systems, automatic dispensing systems, and light-curing systems. Light-curing systems include LED light sources, spot, flood, and conveyor systems designed for compatibility and high performance with Dymax adhesives. Dymax adhesives and light-curing systems optimize the speed of automated assembly, allow for 100% in-line inspection, and increase throughput. System designs enable stand-alone configuration or integration into your existing assembly line.

Please note that most dispensing and curing system applications are unique. Dymax does not warrant the fitness of the product for the intended application. Any warranty applicable to the product, its application, and use is strictly limited to that contained in the Dymax standard Conditions of Sale. Dymax recommends that any intended application be evaluated and tested by the user to ensure that desired performance criteria are satisfied. Dymax is willing to assist users in their performance testing and evaluation. Data sheets are available for valve controllers or pressure pots upon request.

Contents

Introduction	4
Where to Get Help.....	4
Safety	4
General Safety Considerations	5
Specific Safety Considerations.....	5
Product Overview	5
Description of the Model 830 Dispensing Valve.....	5
Special Features and Benefits of the Model 830.....	6
Over-Pinch Adjustment.....	6
Disposable Fluid Path	6
Suck-Back Feature.....	7
Assembly and Setup	7
Unpacking and Inspecting Your Shipment.....	7
Parts Included in the Model 830 Dispensing Valve.....	7
Mounting.....	8
Connecting to Air.....	9
Testing Air Connections	10
Tubing Installation	11
Valve Adjustments.....	12
Spare Parts and Accessories	18
Specifications	21
Warranty	23

Introduction

This guide describes how to set up, use, and maintain a Dymax Model 830 dispensing valve safely and efficiently.

Intended Audience

Dymax prepared this user guide for experienced process engineers, technicians, and manufacturing personnel. If you are new to pneumatically operated fluid dispensing equipment and do not understand the instructions, contact Dymax Application Engineering for answers your questions before using the equipment.

Where to Get Help

Customer Support and Applications Engineering teams are available by phone and email in Germany, Monday through Friday, from 8:00 a.m. to 5:00 p.m. Central European Time. You can also email Dymax Europe GmbH at info_de@dymax.com. Please see the back cover for worldwide contact information. For more information about this product, visit dymax.com.

Additional resources are available to ensure a trouble-free experience with our products:

- “How To” videos and detailed product information on dymax.com
- Dymax adhesive Product Data Sheets (PDS) on our website
- Material Safety Data Sheets (SDS) provided with shipments of Dymax adhesives

Safety



WARNING! *If you use this fluid dispensing equipment without first reading and understanding the information in this guide, personal injury can result from the uncontrolled release of high-pressure gas, injection injury, or exposure to chemicals. To reduce the risk of injury, read and understand this guide before assembling and using Dymax fluid dispensing equipment.*

General Safety Considerations

All users of Dymax fluid dispensing equipment should read and understand this user guide before assembling and using the equipment.

To learn about the safe handling and use of dispensing fluids, obtain and read the SDS for each fluid before using the fluid. Dymax includes an SDS with each adhesive sold. SDS for Dymax products can be requested on the Dymax website.

Specific Safety Considerations

Using Safe Operating Pressures

Pressurizing the components in the dispensing system beyond the maximum recommended pressure can result in the rupturing of components and serious personal injury. To minimize the risk of rupturing components and injury, do not exceed the maximum operating pressure of the components in your fluid dispensing system (see system specifications on page 19).

Preventing Injection Injury

Discharging fluids or compressed air with a dispensing tip against your skin can cause very serious injection injury. To minimize the risk of injection injury, do not place the dispensing tip in contact with your skin.

Product Overview

Description of the Model 830 Dispensing Valve

The Model 830 pinch valve is a normally closed, disposable fluid path valve designed to provide larger flow rates while still maintaining precise flow control. This dual-piston pinch valve works great with many low- to medium-viscosity materials and features a suck-back control so it can handle stringy and tacky materials with no mess.

The 830 pinch valve can be controlled by a digital controller, such as the DVC-345 digital valve controller, or by a three-way, normally closed solenoid valve.

Special Features and Benefits of the Model 830

Feature	Benefit
Over-Pinch Adjustment	Prevents tubing damage, allowing users to achieve millions of cycles from tubing before replacement is required
Disposable Fluid Path	Eliminates material contamination during dispense
	Prevents air entrapment during dispensing process
	Allows for easy product changeover with minimal cleanup
	The valve's inner components never come in contact with fluid, reducing valve maintenance and extending valve life
Adjustable Suck Back	Allows a clean shutoff of thick, tacky, and/or stringy materials
	Minimizes skinning over of the dispense tip
Normally Closed Valve	Keeps the valve closed when there is a pressure drop, eliminating spills

Over-Pinch Adjustment

Dymax disposable fluid path valves all contain a unique over-pinch adjustment. This feature prevents damage to the fluid path, extending the life of the tubing and reducing how often it needs to be replaced.

Disposable Fluid Path

The Model 830 valve features a disposable fluid path constructed out of tubing. Fluids are carried from the material reservoir to the dispense tip in a completely sealed path, ensuring no fluid contact with the valve. This reduces wear on the valve's inner parts, reducing maintenance and extending the valve's life. It also insures that fluids remain contaminate free throughout the dispensing process.

The Model 830 is compatible with a variety of different tubing sizes and materials to ensure complete compatibility with the fluid being dispensed. The disposable fluid path is easy to replace and change out, allowing for easy material changeover with little or no cleanup.

Suck-Back Feature

The suck-back feature on the 830 valve allows for clean shutoff of stringy and tacky materials and prevents the formation of a droplet at the end of the dispense nozzle. The suck-back feature also minimizes the "skinning" over of materials that tend to dry out at the end of the nozzle.

Assembly and Setup

Unpacking and Inspecting Your Shipment

When your Model 830 dispensing valve arrives, inspect the boxes for damage and notify the shipper of box damage immediately.

Open each box and check for equipment damage. If parts are damaged, notify the shipper and submit a claim for the damaged parts. Contact Dymax so that new parts can be shipped to you immediately.

Check that the parts included in your order match those listed below. If parts are missing, contact your local Dymax representative or Dymax Customer Support to resolve the problem.

Parts Included in the Model 830 Dispensing Valve

- Model 830 pinch valve
- Allen Key Set – 3/32" & 9/64"
- Fitting Kit – includes a 5/32" tee, a 1/4" tee, and 5/32" tubing
- Model 830 user guide

Figure 1.
Model 830 Pinch Valve



Mounting

Note: If the dispense valve is to be mounted in an area that limits access to the valve, it is recommended that the setup operation be done prior to mounting. Access to various surfaces of the valve is necessary for periodic adjustment (see Specifications).

There is a clearance hole for a 1/4" [M6] screw and two 1/8" [3.175 mm] locating pin holes on each side of the valve for mounting. See Figure 15 for mounting dimensions.

Connecting to Air

Once the valve is securely mounted:

1. Connect the ports on the valve (Figure 2) to a tee using the 5/32" tubing provided. Select the tee based on the air supply line to the valve. If necessary, make a square cut on the tubing using a sharp, clean tube cutter or a pair of scissors.
2. Connect the tee to the Normally Closed (N.C.) port of the Dymax Model 345 Digital Valve Controller or a 3-way pneumatic switch (neither are included).
3. Connect the air supply (60-100 psi [4.2- 6.9 bar]) to the supply port of the 345 Controller or the 3-way switch.

Figure 2.
Air-In Port



Testing Air Connections

After making all of the air connections, check system for proper connections and operation.

Remove the Tube Support (Figure 5, B) from the Valve Body (Figure 5, A) by removing the four Socket Head Cap Screws (Figure 5, D).

1. Turn on the air supply (60-100 psi [4.2- 6.9 bar]) to the supply port of the 345 Controller or the 3-way valve.
2. Check for any air leaks (hissing). If necessary, shut off supply air and address any leaks.
3. Check that the pinch piston is extended and the suck-back piston is retracted (Figure 3).

Figure 3.
Piston Positions



4. Set the 345 Controller (or 3-way switch) to dispense mode.
5. Check for any air leaks (hissing) again. If necessary, shut off supply air and address any leaks.

6. Check that the pinch piston retracts and the suck-back piston extends (Figure 4). Toggle the dispense function to confirm the two pistons move as described. If necessary, check connections, increase supply pressure to at least 60-100 psi (4.2- 6.9 bar), and try again before contacting Dymax for support.

Figure 4.
Piston Positions



Tubing Installation

Note: The Model 830 is not supplied with tubing. Polyethylene tubing is available for order through Dymax. This valve is compatible with a tubing size of 0.375" [9.53 mm] OD.

1. Separate the Tube Support (Figure 5, B) from the Valve Body (Figure 5, A) by removing the four Socket Head Cap Screws (Figure 5, D).
2. Place the Tubing (Figure 5, C) in the slot (Figure 5, E) on the Tube Support.
3. Reconnect the Tube Support to the Valve Body by reinstalling the four Socket Head Cap Screws evenly with the supplied lock washers.

Note: Since the 830 valve is a N.C. valve, a small amount of resistance when tightening the four Socket Head Cap Screws is normal due to the compressing of the fluid line. When elbows and arms are required to tighten the screws, stop, remove the screws, inspect the threads, and check for cross-threading.

Figure 5.
Tubing Installation Procedure

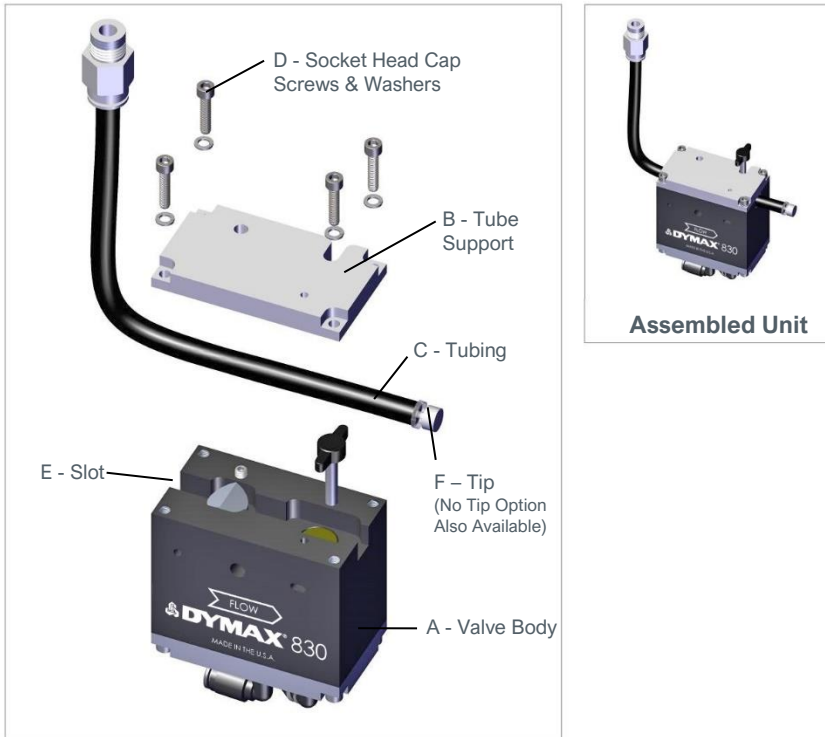

Valve Adjustments

Due to the versatility of the valve, Dymax recommends making sample shots (dispense cycle) and following the chart below to find the correct settings. The chart can also be used as a troubleshooting guide.

Table 1.
Adjustment Chart for Model 830 Dispensing Valve

Problem	Possible Cause	Corrective Action
The valve does not dispense anything or dispense rate is too slow	The supply air pressure to the valve is too low	Increase the supply air pressure to the valve (60-100 psi [4.2- 6.9 bar])
	The fluid pressure is too low	Increase the fluid pressure (100 psi [6.9 bar] max). See reservoir manual for instructions
	The dispense tip gauge is too small	Replace the dispense tip with a larger size tip
	Flow Adjustment is set too low	Increase flow adjustment. See page 15.
	Material Reservoir is low or empty	Refill material
	Material is cured in the tip	Disassemble and clean or replace the tip
	System not configured properly	Re-test air connections. See page 10.
The dispense rate is too fast	The fluid pressure is set too high	Decrease the fluid pressure. See reservoir manual for instructions
	The dispense tip gauge is too large	Replace the dispense tip with a smaller size tip
	Flow Adjustment is set too high	Decrease Flow Adjustment. See page 15
Material leaks from the valve tip or spits	Suck-Back Adjustment is set too low	Increase Suck-Back Adjustment. See page 16
	Flow Adjustment is set too high	Decrease Flow Adjustment. See page 15.
	Over Pinch Protection is set too high	Correct Over Pinch Protection. See page 17.
	Suck-Back Correction is set too high	Reduce Suck-Back Correction. See page 16.
	There is air in the fluid line	See below

Problem	Possible Cause	Corrective Action
There are air bubbles in the fluid (line)	The valve is not properly purged	During setup of a new batch, cycle the valve until the air bubbles are removed
	There is too much suck back	Reduce suck-back adjustment. See page 16
	There is air in the material	Review procedure for filling the material cartridge
	Material Reservoir is low or empty	Refill material
	There is a problem with the material reservoir and the fluid delivery system	Diagnose and repair
Material tube ruptured	Life of the material tube has been exceeded	Replace the material tube at regular intervals
	Over pinch protection is set too low	Correct Over Pinch Protection. See page 17

Figure 6.
Model 830 Cross Section (Flow from Right to Left)

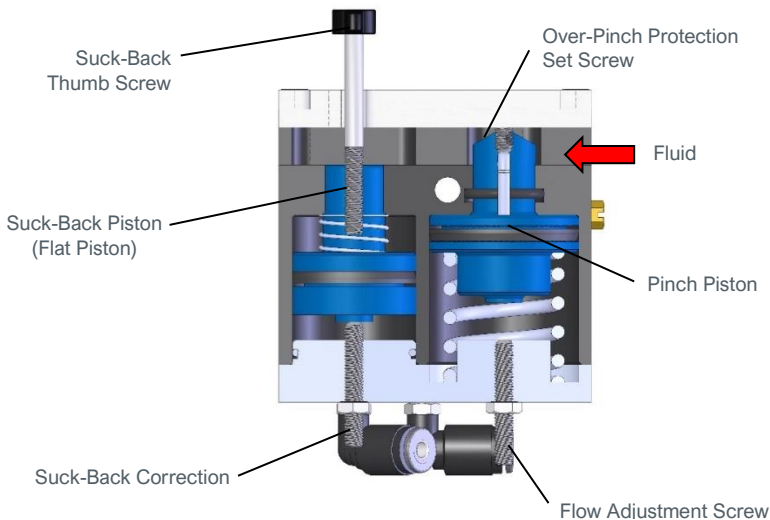

Reduce Flow Adjustment

To reduce Flow Adjustment, loosen the lock nut and turn the Flow Adjustment Screw clockwise. Retighten the lock nut when the desired setting has been achieved. See Figure 7.

Note: Reducing the Flow Adjustment affects the suck-back setting. Suck-back may need to be reduced.

Increase Flow Adjustment

To increase Flow Adjustment, loosen the lock nut and turn the Flow Adjustment Screw counter-clockwise. Retighten the lock nut when the desired setting has been achieved. See Figure 8.

Note: Increasing the Flow Adjustment affects the suck-back setting. Suck-back may need to be increased.

Figure 7.
Reducing Flow Control



Figure 8.
Increasing Flow Control



Reduce Suck-Back Adjustment

To reduce Suck-Back Adjustment, turn the Suck-Back Thumb Screw clockwise. See Figure 9.

Figure 9.
Reducing Suck Back



Increase Suck-Back Adjustment

To increase Suck-Back Adjustment, turn the Suck-Back Thumb Screw counter-clockwise. See Figure 10.

Note: The flow adjustment is also a coarse suck-back adjustment. If additional suck-back is needed, reduce the flow adjustment (See page 14) and fine tune using the suck-back adjustment.

Figure 10.
Increasing Suck Back



Correct Over-Pinch Protection

To correct Over-Pinch Protection, turn the Over-Pinch Protection set screw clockwise until material leaks from the tube. Turn the set screw counter-clockwise until the material barely stops leaking from the tube. Turn the set screw counter-clockwise an additional 1/8 of a turn.

Figure 11.
Correcting Over-Pinch Protection

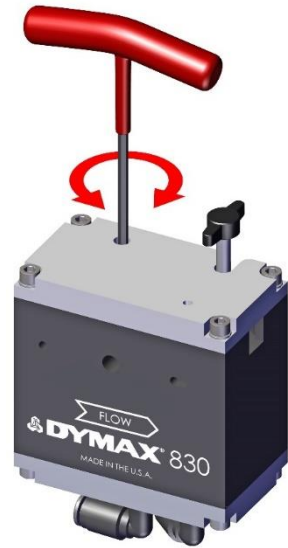

Reduce Suck-Back Correction

To reduce Suck-Back Correction, shut down the material pressure. Remove the valve from the fluid path. With the air pressure and tube support block off, loosen the lock nut and turn the Suck-Back Correction Screw counter-clockwise until the Suck-Back piston is flush with the channel for the fluid path. Retighten the lock nut. See Figure 12.

Figure 12.
Reducing Suck-Back Correction



Spare Parts and Accessories

Item	Part Number
Air Regulators	
Filter Regulator	T16307
High-Precision Regulator	T16629
Controllers	
DVC-345 Digital Valve Controller	T11146
 tubing & Fittings (See Figure 14)	
Material Fluid Path, w/ Luer-Lock Fitting and 1/8" NPT, 8.5" long, .375" OD PE tube	T15225
Material Fluid Path, w/ 1/8" NPT, 8.5" long, .375" OD PE, for use with custom tips	T18305
.375" OD PE tube, by the foot	T15878
Fitting, Luer-Lock Female to Barb, for use with .375" OD PE tubing	T11978
Fitting, 1/8" NPT to quick connect, for use with .375" OD PE tubing	T15233
Misc.	
Model 830 Wrench Set	T18221
Hardware Kit (See Figure 13)	T18304
Valve Fittings Kit, Includes: 1/4 x 5/32 Tee Fitting, 5/32 Tee Fitting, and 5/32 OD Blue Tubing (1 ft.)	T18510
24" Lab Stand for Mounting Reservoirs and Valves	T15279
Model 830 Valve Mounting Assembly, for use with stand T15279	T18411



Filter Regulator
T16307



High-Precision Regulator
T16629



DVC-345 Valve Controller
T11146

Figure 13.
Model 830, Exploded View

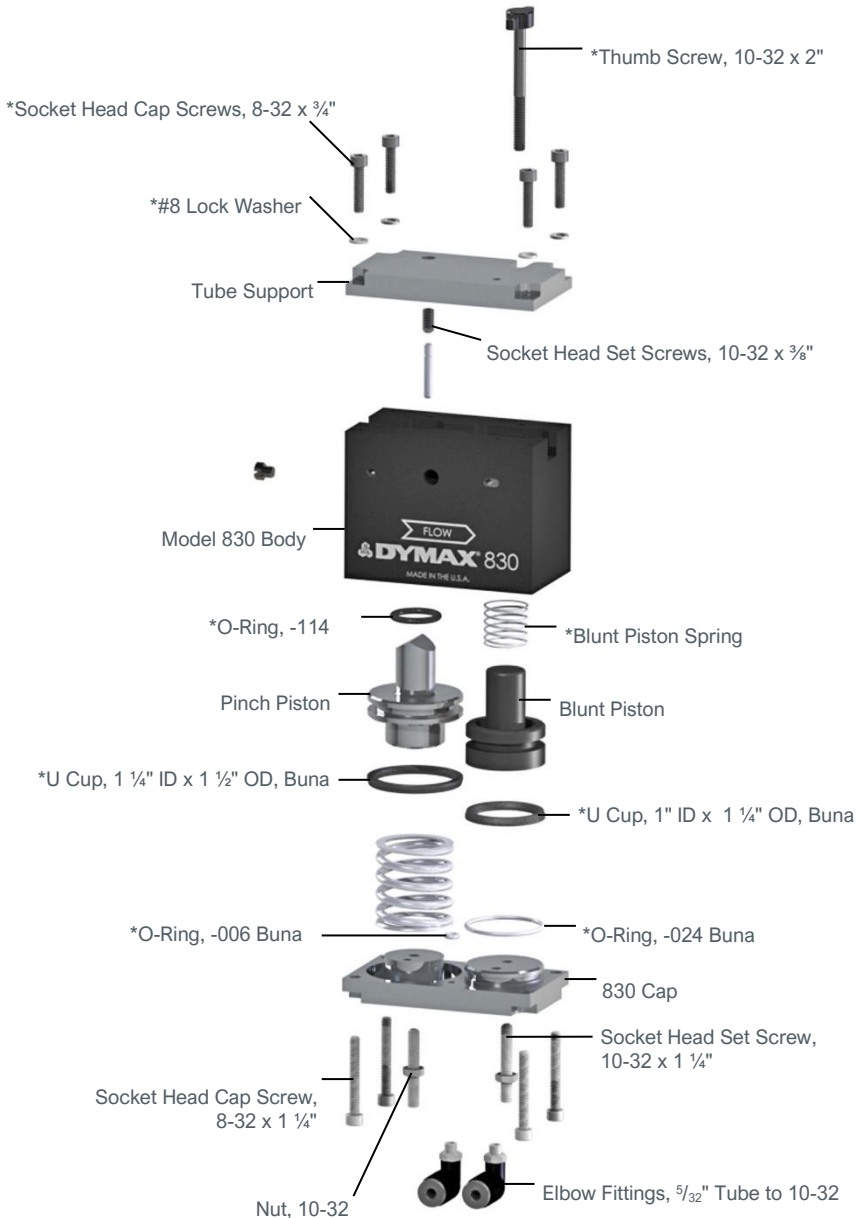

* Included in hardware kit **T18304**

Figure 14.
Tubing Assembly

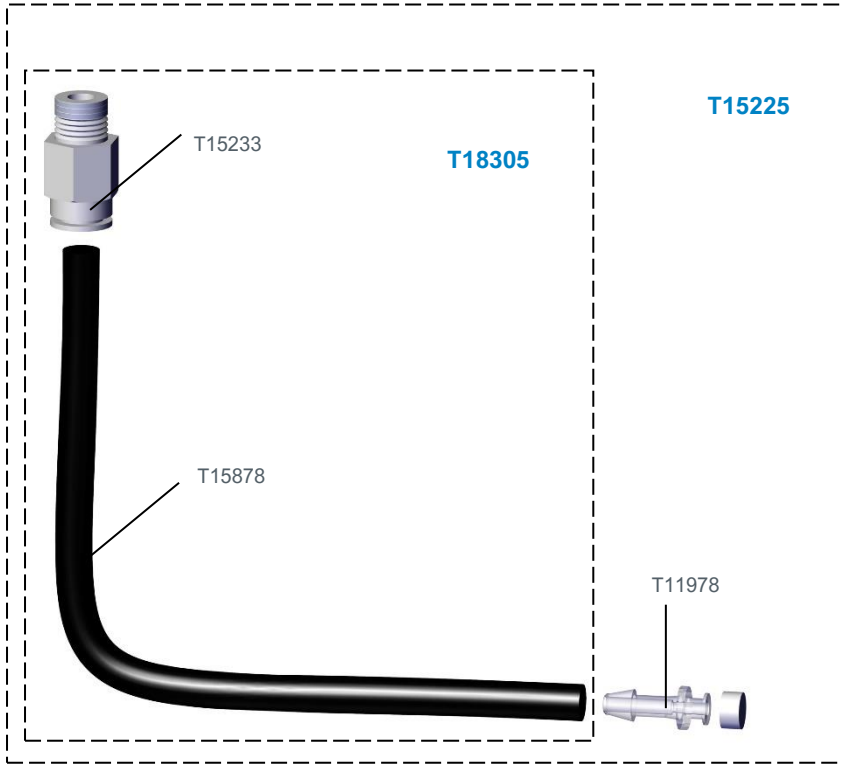

Specifications

Property	Specification
Part Number	T18196
Valve Type	Normally closed pinch valve with disposable fluid path
Construction Material	Anodized aluminum
Operating Air Pressure	60-100 psi [4.2-6.9 bar]
Air Inlet	Accepts 0.156" [0.40 cm] OD, others available
Maximum Tubing Size	0.375" (9.53 mm) OD
Maximum Inlet Fluid Pressure	Up to 100 psi [6.9 bar] typical
Maximum Operating Temperature	104°F [40°C]
Activation	Valve controller or 3-way normally closed solenoid valve
Dimensions (W x H x D)	With fittings & hardware: 4.75" x 3.25" x 1.75" [12.1 cm x 8.25 cm x 4.45 cm] Valve body only: 3.125" X 3.125" x 1.75" [7.94 mm x 7.94 mm x 4.45 cm]
Weight	1.5 lbs. [0.68 kg]
Unit Warranty	1 year from purchase date

Figure 15.
Dimensions

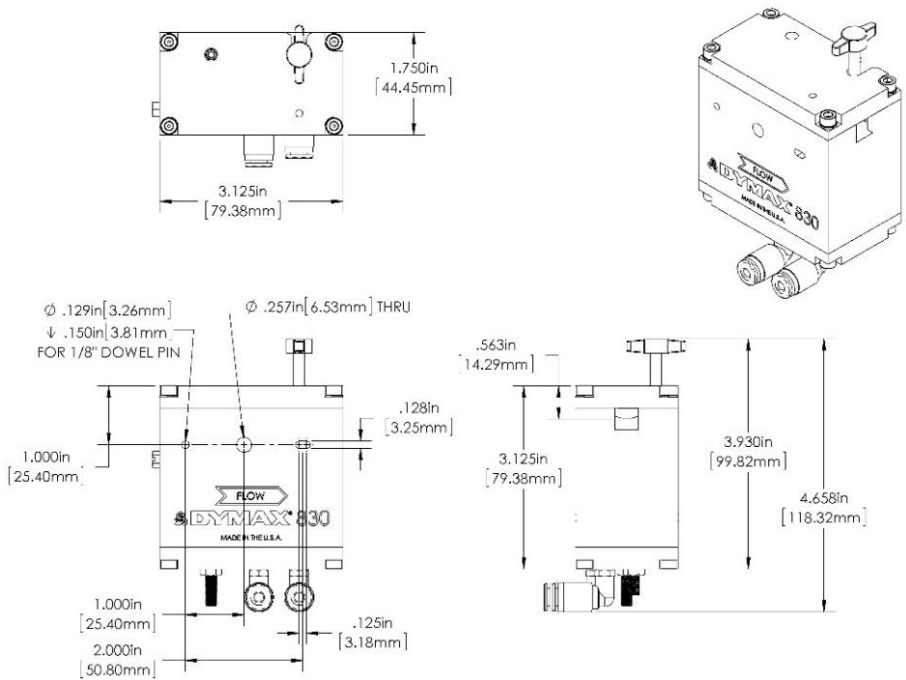

Warranty

From date of purchase, Dymax Corporation offers a one-year warranty against defects in material and workmanship on all system components with proof of purchase and purchase date.

Unauthorized repair, modification, or improper use of equipment may void your warranty benefits. The use of aftermarket replacement parts not supplied or approved by Dymax Corporation will void any effective warranties and may result in damage to the equipment.

IMPORTANT NOTE: DYMAX CORPORATION RESERVES THE RIGHT TO INVALIDATE ANY WARRANTIES, EXPRESSED OR IMPLIED, DUE TO ANY REPAIRS PERFORMED OR ATTEMPTED ON DYMAX EQUIPMENT WITHOUT WRITTEN AUTHORIZATION FROM DYMAX. THOSE CORRECTIVE ACTIONS LISTED ABOVE ARE LIMITED TO THIS AUTHORIZATION.



Americas

USA | +1.860.482.1010 | info@dymax.com

Europe

Germany | +49 611.962.7900 | info_de@dymax.com
Ireland | +353 21.237.3016 | info_ie@dymax.com

Asia

Singapore | +65.67522887 | info_ap@dymax.com
Shanghai | +86.21.37285759 | dymaxasia@dymax.com
Shenzhen | +86.755.83485759 | dymaxasia@dymax.com
Hong Kong | +852.2460.7038 | dymaxasia@dymax.com
Korea | +82.31.608.3434 | info_kr@dymax.com

© 2015-2019 Dymax Corporation. All rights reserved. All trademarks in this guide, except where noted, are the property of, or used under license by Dymax Corporation, U.S.A. Teflon is a registered trademark of DuPont.

The data contained in this bulletin is of a general nature and is based on laboratory test conditions. Dymax Europe GmbH does not warrant the data contained in this bulletin. Any warranty applicable to products, its application and use is strictly limited to that contained in Dymax Europe GmbH's General Terms and Conditions of Sale published on our website. Dymax Europe GmbH does not assume any responsibility for test or performance results obtained by users. It is the user's responsibility to determine the suitability for the product application and purposes and the suitability for use in the user's intended manufacturing apparatus and methods. The user should adopt such precautions and use guidelines as may be reasonably advisable or necessary for the protection of property and persons. Nothing in this bulletin shall act as a representation that the product use or application will not infringe a patent owned by someone other than Dymax Corporation or act as a grant of license under any Dymax Corporation Patent. Dymax Europe GmbH recommends that each user adequately test its proposed use and application of the products before actual repetitive use, using the data contained in this bulletin as a general guide. T18198 MAN076EU 7/9/2019