

- Ideal for low- to medium-viscosity materials
- Features a disposable fluid path that carries materials from the material reservoir to the dispense tip, preventing contamination and air entrapment
- Stroke adjustment for precise, micrometer control over dispensing volumes
- Valve design allows for easy product changeover with minimal cleanup
- Fluid never comes into direct contact with the valve, reducing valve maintenance and extending the life of the valve
- Over-pinch adjustment prevents damage to the tube, extending its life, and cutting down on necessary replacement
- Built-in delay system for drip-free operation
- External air-mix design with luer-lock connection allows different gauge tips to be exchanged to adjust flow rate needs across applications
- Compatible with most standard fluid packages and delivery systems
- Lightweight, easy-to-handle and mount in automated or bench-top systems

## Model 455 Micro-Spray Valve

### Micro-Spray Valve Utilizing a Disposable Fluid Path for Contaminate-Free Dispensing and Fast Material Changeover

The Model 455 Micro-Spray Valve is a pneumatic pinch valve outfitted with a stainless steel spray nozzle and spray regulator assembly. The spray nozzle is an external air-mix type which utilizes a standard luer-lock design allowing different gauge tips to be exchanged to adjust flow rate needs. The combination of tip variation and integrated pneumatic controls allows control over the amount of air relative to the amount of fluid. The controls feature a built-in delay system that atomizes the tiny droplet that would normally remain on the nozzle when the valve is shut off. This enhances repeatability and guarantees drip-free operation.

The Model 455 pinch valve utilizes tube over-pinch, a feature that extends tube life, enhances repeatability, and offers precise control over material flow. It also features an inert, 100% disposable fluid path which carries materials from the material reservoir to the spray nozzle in a sealed path. This prevents materials from coming in contact with the valve's inner components and ensures a contaminate-free dispensing process. The fluid path is easy to replace and requires minimum cleanup, allowing for rapid material changeover. The valve can be supplied with fluid paths of varying materials and sizes for optimum material compatibility.

# How the Micro-Spray Valve Works

This system uses air to transport fluids from a material reservoir to the spray nozzle. A disposable fluid path runs from the material reservoir through the valve to the spray nozzle. Air is supplied to the valve by a Dymax DVC-345 digital valve controller or a user-supplied 3-way valve that is connected to the air-in port. The valve activates automatically when the control air is supplied, and remains on until the control air is shut off.

Proper spray volume is achieved by adjusting five (5) parameters: the tip gauge, the fluid pressure, the valve flow control, the atomizing air flow control (controls atomizing air relative to the amount of fluid), and the amount of time the valve is on. Proper adjustment of these items yields a precisely controlled, repetitive spray pattern and dispensed volume. The system is particularly suited to the spraying of low- to medium-viscosity materials. The adjustable tip design also allows for a wide range of spray pattern adjustment.

## Flow Rate/Pattern

The micro-spray valve provides material and flow rates that are typically in the 0.001 to 0.200 mL/min range. The spray pattern of a low-viscosity material is approximately a 14-degree conical pattern as shown in Figure 1.

Figure 1. Model 455 Spray Valve

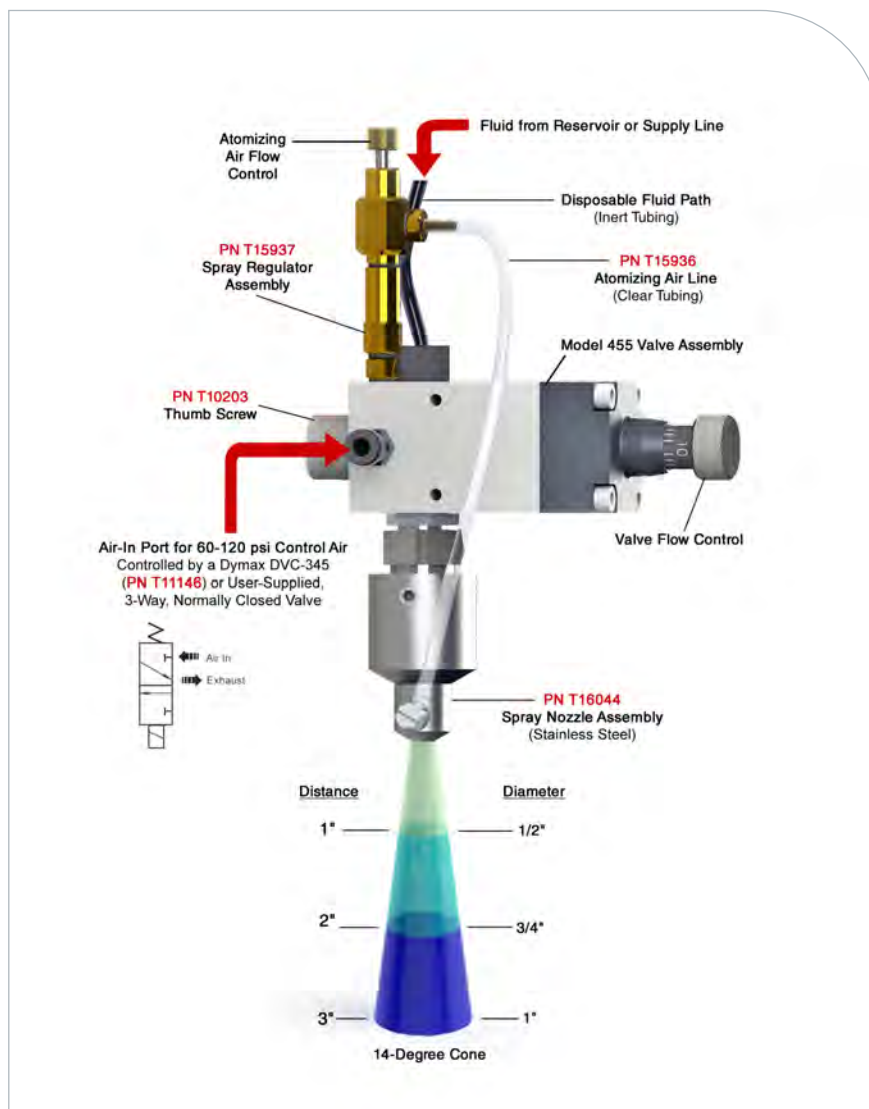

# Specifications

Specifications	
Part Numbers	<p><b>T18001</b> Model 455 Spray Nozzle Kit</p> <p><b>T18002</b> Model 455 Spray with 0.066 in black PTFE tubing</p> <p><b>T18000</b> Model 455 Spray with 0.095 in black PTFE tubing</p> <p><b>T18004</b> Model 455 Spray with 0.125 in black PE tubing</p>
Performance Requirements	Low-viscosity (< 5,000 cP), low-pressure (< 30 psi) applications
Valve Type	Pneumatic pinch valve, normally closed
Valve Materials	Anodized Aluminum
Operating Air Pressure	60-90 psi (4.14 – 6.21 bar)
Activation	DVC-345 valve controller or 3-way solenoid valve
Maximum Inlet Fluid Pressure	Tubing dependent; 100 psi (6.89 bar) max
Electrical Supply (Controller)	110/220 VAC
Maximum Operating Temp.	350°F (177°C) w/PTFE tubing
Air Inlet Maximum Tubing Size	0.25" (6.35 mm) OD
Typical Flow Rates with Water	<p>0.125" (3.17 mm) ID tubing – 30 mL/sec</p> <p>0.095" (2.41 mm) ID tubing – 15 mL/sec</p>
Valve Dimensions (W x H x D)	3.75" x 4" x 5" (9.53 cm x 10.16 cm x 12.75 cm)
Valve Weight	5.5 oz (146 g)
Warranty	1 year from purchase

